



[I-21/119/2024-W&M Section]
GOVERNMENT OF INDIA/भारत सरकार
MINISTRY OF CONSUMER AFFAIRS, FOOD AND PUBLIC DISTRIBUTION
उपभोक्ता मामले, खाद्य एवं सार्वजनिक वितरण मंत्रालय
DEPARTMENT OF CONSUMER AFFAIRS/ उपभोक्ता मामले विभाग
LEGAL METROLOGY DIVISION/ विधिक मापविज्ञान प्रभाग
Krishi Bhawan/कृषि भवन, नई दिल्ली
Dated/दिनांक:- 06 .05.2024

Certificate of Approval of Model/ मॉडल का अनुमोदन प्रमाणपत्र

Whereas the Central Government, after considering the report submitted to it by the prescribed authority, is satisfied that the model described in the said report is in conformity with the provisions of the Legal Metrology Act, 2009 (1 of 2010) and the Legal Metrology (Approval of Models) Rules, 2011 and the said model is likely to maintain its accuracy over periods of sustained use and to render accurate service under varied conditions;

Now, therefore, in exercise of the powers conferred by section 22 of the Legal Metrology Act, 2009 (1 of 2010) read with sub-rule (6) of rule 8 and sub-rule (4) of rule 11 of the Legal Metrology (Approval of Models) Rules, 2011, as per Schedule Seventh of the Legal Metrology (General) Rules, 2011, the Central Government hereby issues the certificate of approval of the model of non-automatic weighing instrument with digital indication of ordinary accuracy (accuracy class-III) of series "BWEH" and with brand name "WIC" (hereafter in this notification referred to as the said model), manufactured by M/s Weighing India Corporation, 155/230/232, Jangalpur Road, Kolkata-700081 (North 24 Parganas) (West Bengal) and which is assigned the approval mark IND/09/24/ 213 (the picture of model is given below as figure 1);

The said model is a spring and lever based mechanical non-automatic weighing instrument with a maximum capacity of 10kg and minimum capacity of 1kg. The verification scale interval (e) is 100g. The analog (Dial type) with graduated scale and pointer indicates the results of measurements. It is baby weighing scale type weighing instrument.

Figure 1

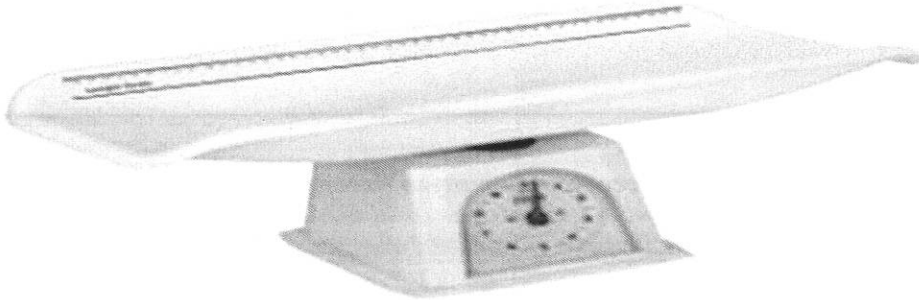

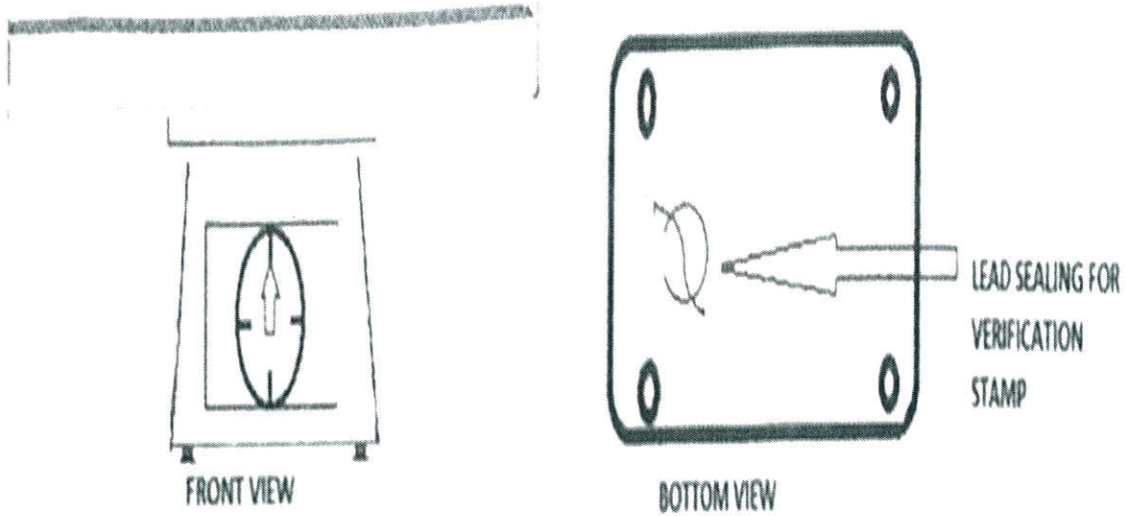

Figure 2

The sealing is done by applying lead and seal wire through the body of machine. Sealing is done to prevent the opening of the weighing machine for fraudulent practice. (a typical schematic diagram of sealing provision of the model is given above as figure 2).

Further, in exercise of the power conferred by sub-rule (9) of rule 8 of the Legal Metrology (Approval of Models) Rules, 2011, the Central Government hereby declares that this certificate of approval of the said model shall also cover the weighing instruments of similar make, accuracy and performance of same series with maximum capacity up to 50kg with number of verification scale interval (n) in the range of 100 to 1,000 for 'e' value of 5g or more and with 'e' value of 1×10^k , 2×10^k or 5×10^k , where k is a positive or negative whole number or equal to zero manufactured by the same manufacturer in accordance with the same principle, design and with the same materials with which, the said approved model has been manufactured.

[F.No. I-21/119/2024-W&M Section]

Ashutosh Agarwal

Director (Legal Metrology) to Govt. of India/ निदेशक (विधिक माप विज्ञान) भारत सरकार

Phone/दूरभाष 01123389489

Email/ई-मेल: dirwm-ca@nic.in

Online Application No. 18474